

OFFICIAL MILK ANALYSIS IN CANADA.

BY PROF. W. H. ELLIS.

During the summer of 1887 the Public Analysts of Canada made a number of analyses of samples representing the mixed milk of herds of cows. The cows were milked in the presence of the Analyst and of an officer of the Inland Revenue Department, and duplicate samples taken by them, one of which was examined by the Public Analyst and the other sent to Ottawa and there analyzed by the Chief Analyst, Mr. Macfarlane.

Particular attention was paid to seeing that the cows were milked dry, and that the sample represented the whole milk of the herd. The milk from 167 herds was analyzed, which, if we assume the average number of cows in a herd to be six,* will represent the milk of about a thousand cows.

The Chief Analyst's results were as follows :

	Average.
Solids	12.82
Fat	3.86
Solids not fat.....	8.96

The examination of the milk from the neighborhood of Toronto fell to my lot. I examined the milk of 37 herds, comprising more than 390 cows. The samples were analyzed by the method pre-

* This is below the truth. The instructions were that no herd of less than four cows was to be examined.

scribed by the Society of Public Analysts for Great Britain (*Analyst*, 1885, p. 46).

The total solids were dried on the water bath in flat bottomed platinum dishes to constant weight.

To determine the fat, milk was run into a stoppered weighing bottle, absorbed by a fat free paper coil, and the quantity of milk absorbed determined by the loss of weight. This coil was then dried in a water oven for one hour, exhausted in a Soxhlet apparatus with light petroleum, the petroleum evaporated and the fat weighed in a light flask after drying to constant weight in a water oven.

My analyses were published in a report to the Canadian government (supplement No. 111 to the report of the Department of Inland Revenue, 1888).

My results may be expressed as follows.

	Total Solids.	Fat.	Solids not fat.
Maximum.....	13.48	4.87	9.26
Mean.....	12.27	3.56	8.71
Minimum.....	10.77	2.70	8.00

The duplicate samples were analysed at Ottawa in the Chief Analyst's laboratory with the following results:

	Total Solids.	Fat.	Solids not fat.
Maximum.....	13.47	4.50	9.28
Mean.....	12.08	3.38	8.70
Minimum.....	10.68	2.52	8.17

The method employed at Ottawa is to weigh the milk into short funnel tubes packed with asbestos, dry in a water oven to get total solids, extract in a Soxhlet or other extraction apparatus large enough to hold several tubes, one above the other, with gasoline, weigh the solids not fat and estimate the fat by difference.

It will be seen that I obtained by the paper method about 0.2% more fat than was got by this asbestos process.

Thinking it desirable to study the effect of drying these finely

divided milk residues under different conditions I devised an oven of which the following is a description :

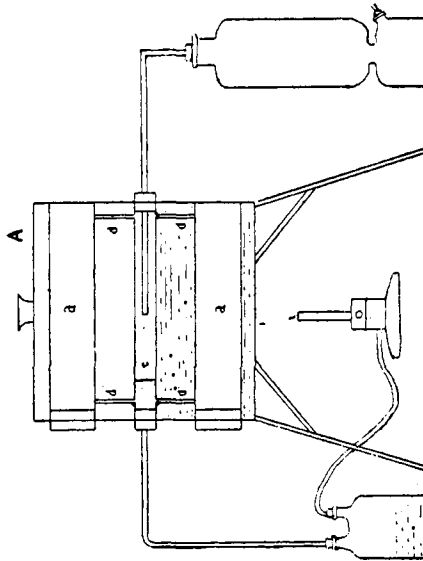
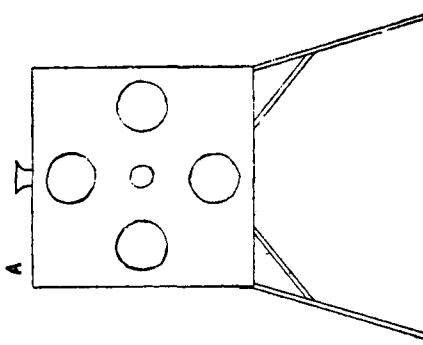

A is a copper box each side of which measures 9 inches. Four tubes a, a, a, a, run through it from front to back, $2\frac{1}{4}$ inches diameter. In front they are open and fitted with corks. Behind they are closed. They serve to hold the asbestos drying tubes, which stand in holes in a strip of copper p, which can be pushed into the tubes a.

A fifth tube, c, runs through the centre of the box from front to back.

It is divided near the front by a partition and connected with each of the drying tubes a, by two connecting tubes d, d¹, one in front of the partition and the other behind it and near the back. Both ends of the tube c are open and fitted with corks. The hinder cork carries a glass tube, which runs almost to the partition and is connected behind with a drying arrangement. The front cork carries a glass tube, which is connected with a Woulf's bottle.

To use the oven with hydrogen the gas is aspirated from a gas-holder through the drying apparatus into the tube c, where it becomes heated; thence it passes into the drying tubes a by the connecting tubes d; there it passes over the samples and back again into c, in front of the partition, by the connecting tubes d¹; thence it passes to the Woulf's bottle, where it deposits most of its moisture and thence to a second gas holder.

With coal gas a drying apparatus is connected with the supply, and the Woulf's bottle is connected with a Bunsen burner beneath the oven, where the gas is burned, serving to boil the water in the oven.

Mr. W. Lawson, a student in my laboratory, has made the following determination with this apparatus:

Eighteen samples of the same milk were weighed out into asbestos tubes at the same time, and within the same hour six of them were put into an ordinary water oven, six into an oven filled with hydrogen, and six into an oven filled with coal gas.

The results were as follows:

		<i>Total Solids.</i>			
	In Air.		In Coal Gas.		In Hydrogen.
No. 1	12.212	No. 7	12.058	No. 13	11.979
2	12.235	8	12.078	14	11.997
3	12.256	9	12.072	15	11.949
4	12.222	10	12.005	16	11.959
5	12.251	11	12.019	17	11.998
6	12.239	12	12.031	18	12.049
Mean	<hr/> 12.235	Mean	<hr/> 12.044	Mean	<hr/> 11.988

Solids not Fat after Extraction with Gasoline.

Air.	Coal Gas.	Hydrogen.
No. 1 8.821	No. 7 8.521	No. 13 8.432
2 8.845	8 8.525	14 8.446
3 8.866	9 8.544	15 8.396
4 8.846	10 8.521	16 8.415
5 8.913	11 8.543	17 8.429
6 8.877	12 8.509	18 8.489
Mean 8.861	Mean 8.527	Mean 8.434

Fat (by Difference).

Air.	Coal Gas.	Hydrogen.
No. 1 3.391	No. 7 3.537	No. 13 3.547
2 3.390	8 3.553	14 3.551
3 3.390	9 3.528	15 3.553
4 3.376	10 3.484	16 3.544
5 3.338	11 3.476	17 3.569
6 3.362	12 3.522	18 3.560
Mean 3.374	Mean 3.517	Mean 3.554

Five determinations of the fat were then made by the Werner-Schmidt method, with the following results:

	Fat per cent.
No. 1	3.543
2	3.560
3	3.613
4	3.539
5	3.595
Mean	3.571

Comparing the averages of these fat determinations we get:

In air by asbestos	3.374	per cent.
In coal gas, by asbestos	3.517	“
In hydrogen, “	3.554	“
By Werner-Schmitt Method	3.571	“

The average percentage of fat in coal gas and hydrogen is.....	3.536
The average in air is.....	3.374
	<hr/>
A deficiency of.....	.162
The average total solids in air are.....	12.235
In hydrogen and coal gas.....	12.016
	<hr/>
An excess of.....	.219
The solids not fat in air are.....	8.861
In hydrogen and coal gas.....	8.480
	<hr/>
An excess of.....	.381

It appears, then, from these experiments that by long drying in the air at the temperature of the water oven, the milk solids undergo changes by which the total solids increase in weight 1.8% and the portion insoluble in gasoline increases in weight 4.3%, while the fat, as determined by difference, loses 4.5%, a part of it apparently becoming insoluble in gasoline.

The asbestos method as used by Mr. McFarlane is, in my judgment, the most simple and rapid gravimetric process at our disposal for the analysis of a number of samples at once. By drying in purified coal gas, in an apparatus such as I have described, it may be made without materially interfering with its simplicity, also, one of the most accurate.